



 **SOLAR SCREEN**  
**STORE D'INTERIEUR**  
SMART BLIND SOLUTIONS



# SOMMAIRE

NOS STORES	4 - 5
NOTRE GAMME	6 - 19
NOS MÉCANISMES	20 - 25
NOS RÉFÉRENCES	26 - 27

# LA FABRICATION



En **France**, sur le site d'Emerainville, chaque store est conçu à la main, sur mesure selon une expertise reconnue et appréciée dans le but d'améliorer le confort et le bien-être des personnes.



**1** CHOIX DES MATÉRIAUX

Nos toiles sont sélectionnées tant pour leur coloris que pour leurs propriétés spécifiques.



**2** TRAVAIL SUR MESURE

Toutes les toiles, toutes les tailles, toutes les formes, chaque demande trouve sa solution.



**3** ASSEMBLAGE

Chaque commande demande précision et maîtrise, les toiles et les mécanismes sont assemblés à la main.



**4** 100% TESTÉS

Dans un souci de qualité et de satisfaction client, tous nos stores sont testés avant chaque envoi.



Une expertise qui dure depuis plus de 30 ans

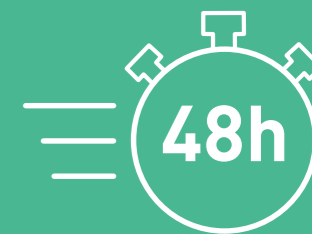

Prototype livré en 48h



Un large réseau de distributeurs dans toute la France

# Problème de **CHALEUR ?**



La chaleur est fortement nuisible à la productivité, au confort et à la santé des personnes.

C'est une problématique majeure grandissante chaque année dans les entreprises.

SOLUTION



## Toile **STORE FILM**



- Toile développée spécialement pour **réduire la température**.
- Jusqu'à **92%** de chaleur rejetée.
- Permet une **bonne continuité visuelle** sur l'extérieur.

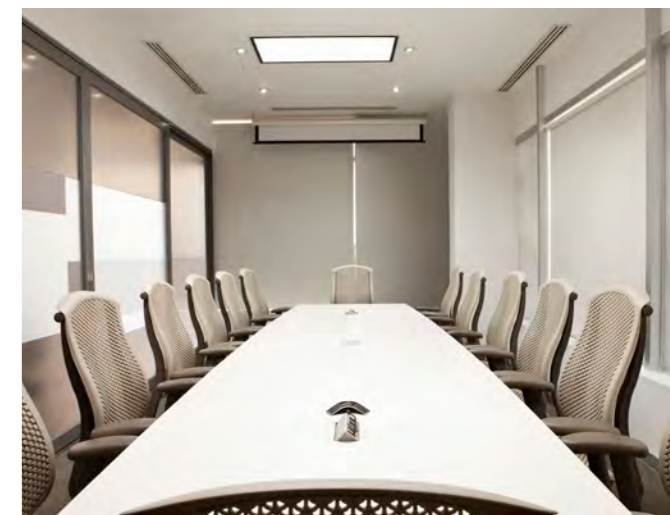



# Problème D'ÉBLOUISSEMENT ?

L'éblouissement est un réel problème pour la concentration et la productivité.

Cela peut causer des maux de tête, un travail plus intense des yeux et un travail de moins bonne qualité.

## SOLUTION



# Toile SOLTIS 99 by Serge Ferrari



- Jusqu'à **97%** d'éblouissement en moins.
- **21 coloris** disponibles en stock.
- Optimise **le confort** en terme de design et de chaleur.



Besoin  
**DE CHANGEMENT ?**

La décoration intérieure est importante, elle permet de rendre plus agréable l'environnement de travail, de se sentir mieux et donc d'être plus productif.

SOLUTION



Toile  
**SCREEN VISION**  
by Mermet



- Offre un **confort visuel et thermique**.
- **14 coloris** disponibles en stock.
- Tissage natté permettant une **transparence optimale**.





Problème  
**D'INTIMITÉ ?**

Au travail, dans les bureaux, nous n'avons pas toujours envie d'être observés.

Pour des raisons de confidentialité, l'intimité doit pouvoir être respectée.

SOLUTION



Toile  
**ÉLYSÉE**



- Pouvoir **se cacher** du vis-à-vis.
- **Habiller** son espace de travail.
- **21 coloris** disponibles.

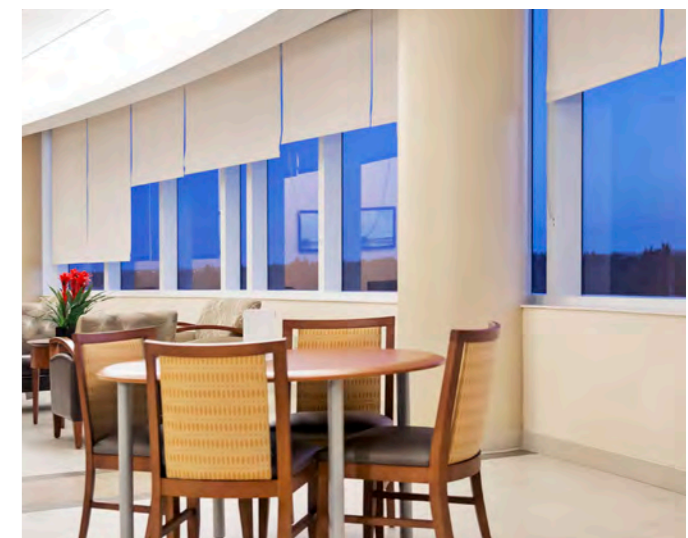

Besoin  
**D'OBSCURITÉ ?**

Trop de lumière dans une pièce peut parfois être dérangent.

Il existe d'autres dispositifs que les volets extérieurs pour obtenir une obscurité totale.

SOLUTION



## Toile **BLACKOUT**



- Permet l'**obscurité totale** d'une pièce.
- Disponible dans de **grandes largeurs** pour éviter les raccords.
- **6 coloris** disponibles.

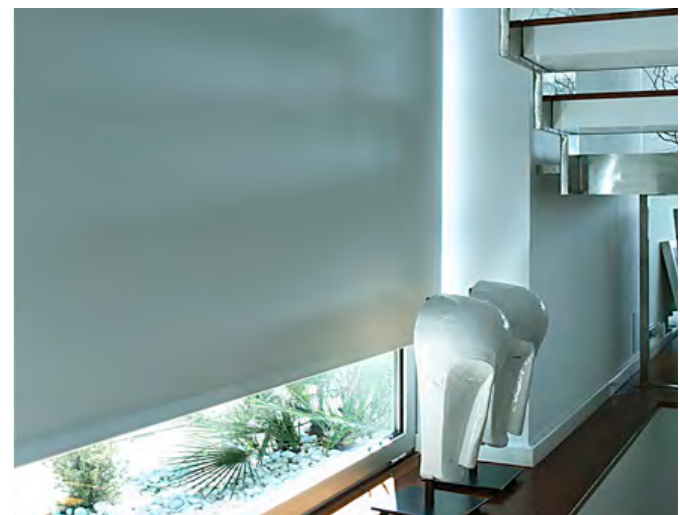



# Besoin de **VOIR SANS ÊTRE VU ?**

La problématique de l'intimité extérieure est importante au travail.

Le besoin d'allier discrétion et design rassure tout en étant apprécié de tous.

SOLUTION

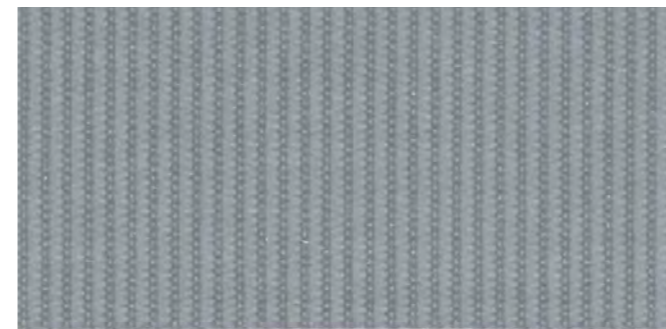

## Toile **RIVOLI**



- **2 positions** possibles : jour et nuit pour associer luminosité et discrétion.
- **7 coloris** disponibles.
- La **touche design** pour votre intérieur.





L'intimité permet une meilleure confidentialité.

Il est cependant difficile pour les entreprises de trouver un moyen peu coûteux pour accéder à cette solution.

SOLUTION

Besoin d'une solution  
**À MOINDRE COÛT ?**



# Store VÉNITIEN



- Contribue à l'intimité et est **anti vis-à-vis**.
- **S'intègre facilement** dans les chassis.
- Plus de **100 coloris** disponibles.



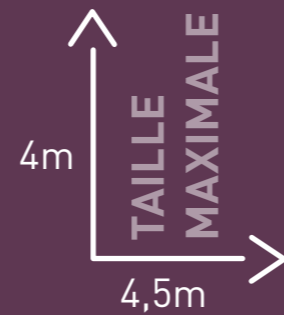
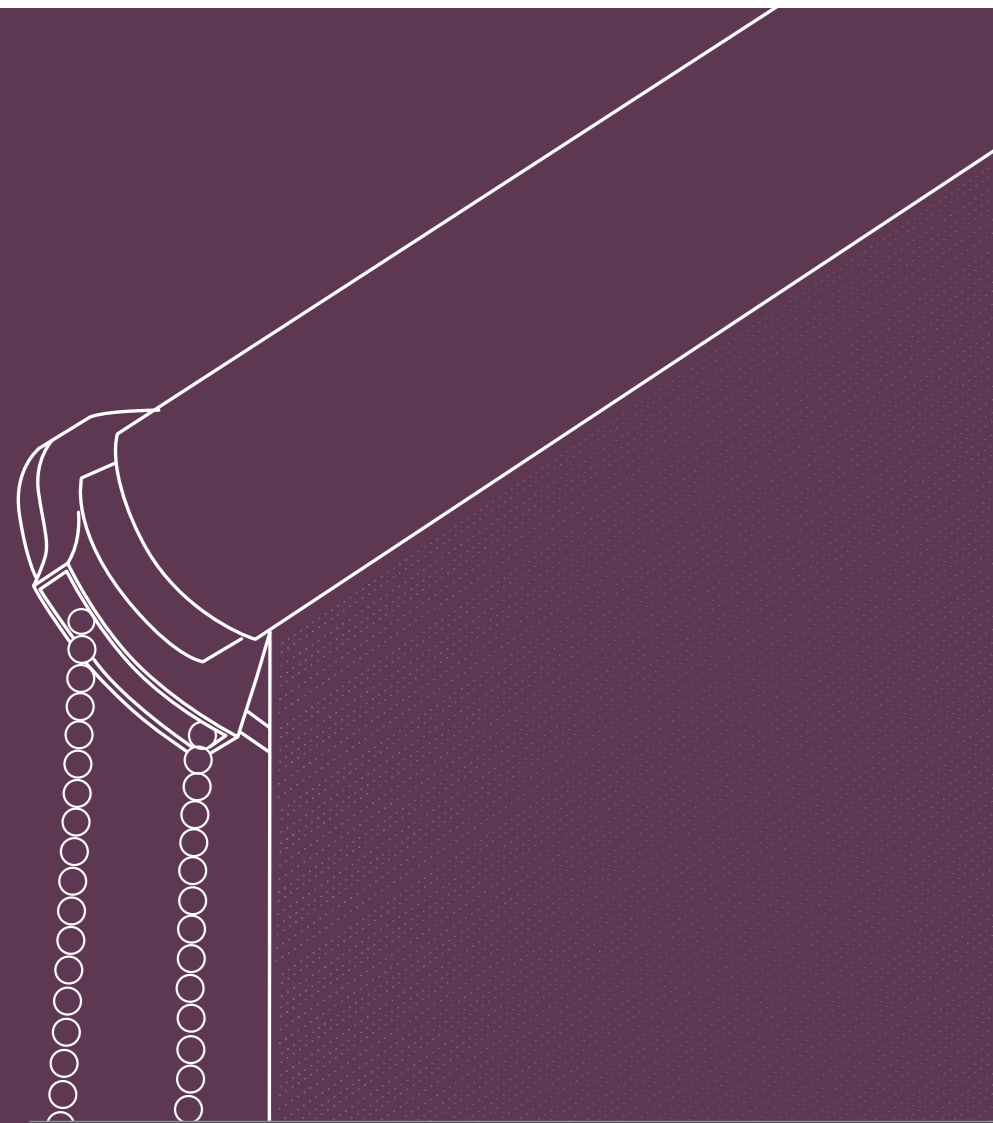

# STORES ENROULEURS

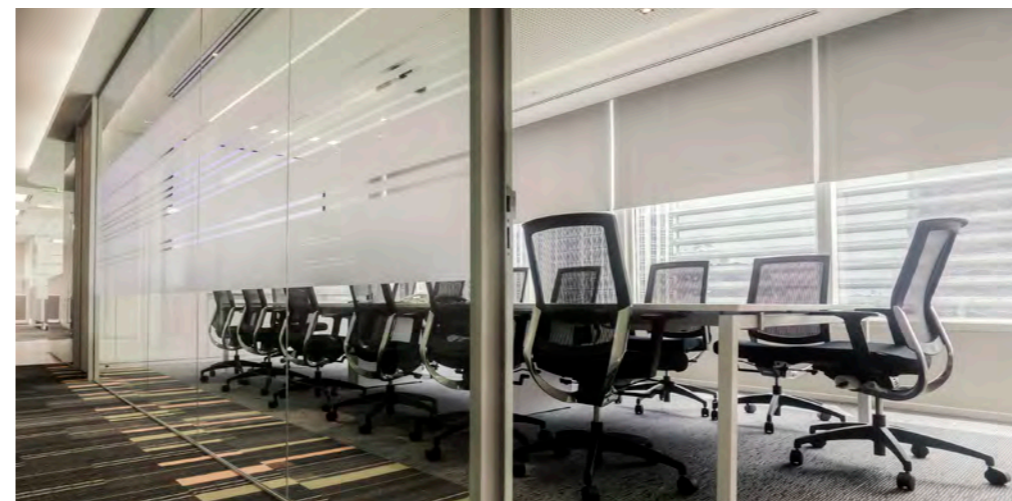

## OPTIONS

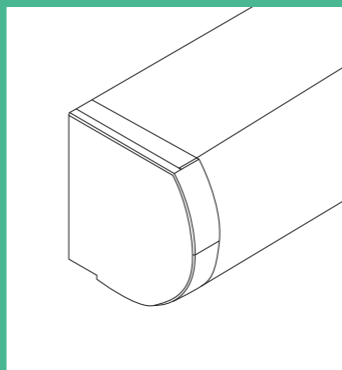

BOX

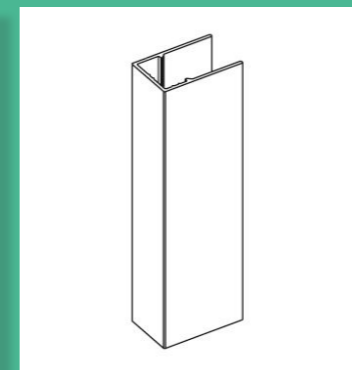

GLISSIÈRE U OU COFFRET

## MECANISMES



CHAINETTE NICKEL OU PVC

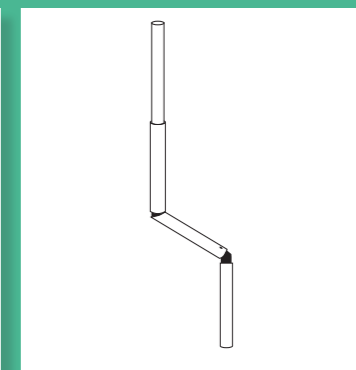

TREUIL

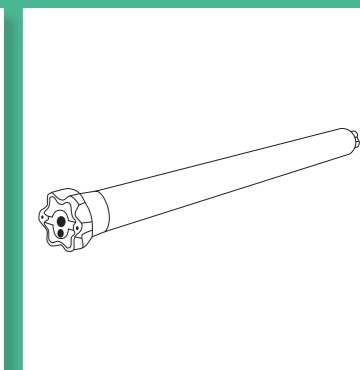

MOTEUR

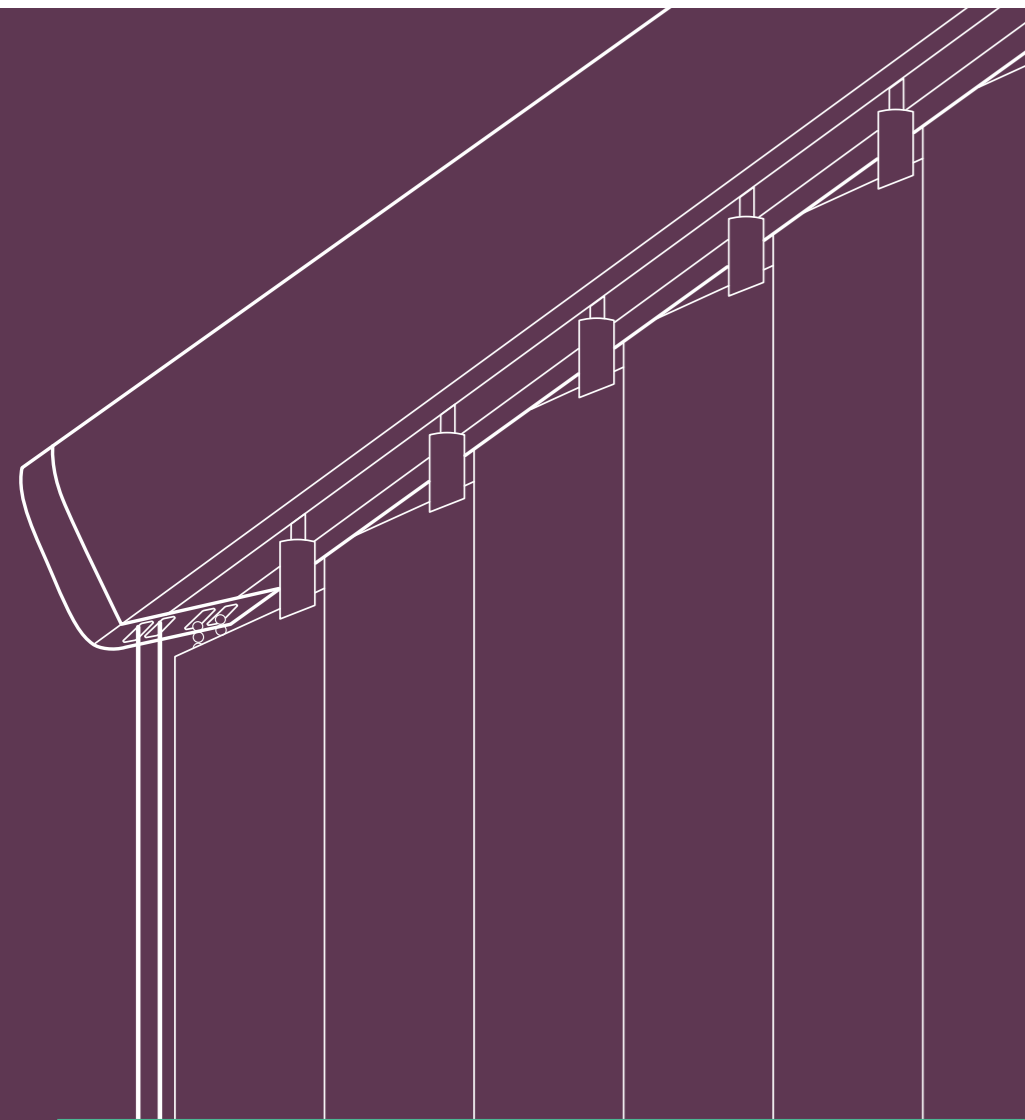

4m  
 TAILLE  
 MAXIMALE  
 6m

# STORES À BANDES

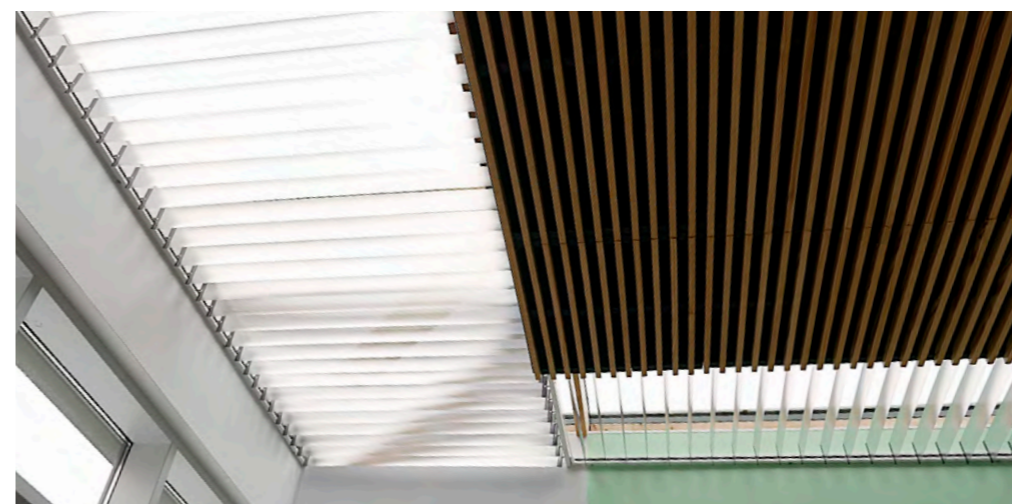

PERFORMANCE  
 ET FLEXIBILITÉ

## OPTIONS

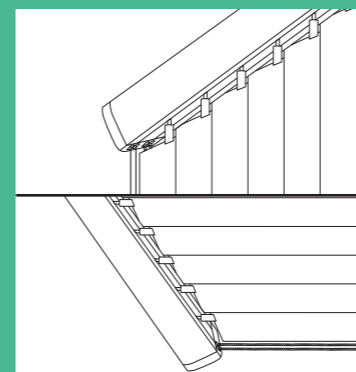

VERTICALES OU  
 HORIZONTALES

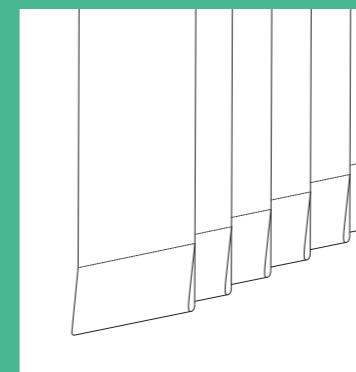

89, 127 OU 250MM

## MECANISMES

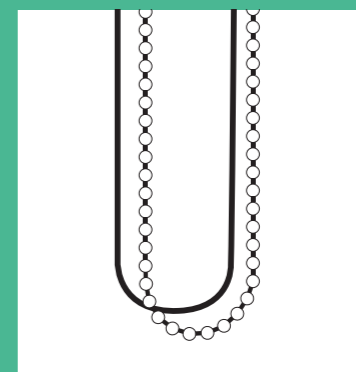

CORDON ET CHAINETTE



MONOCOMMANDE

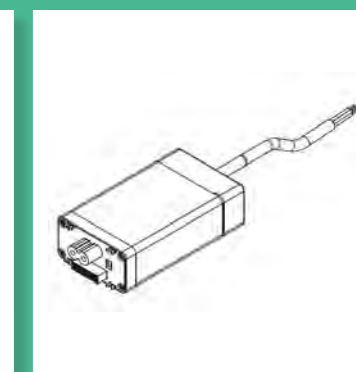

MOTEUR

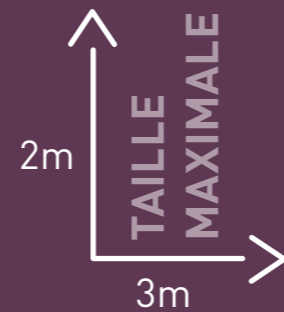
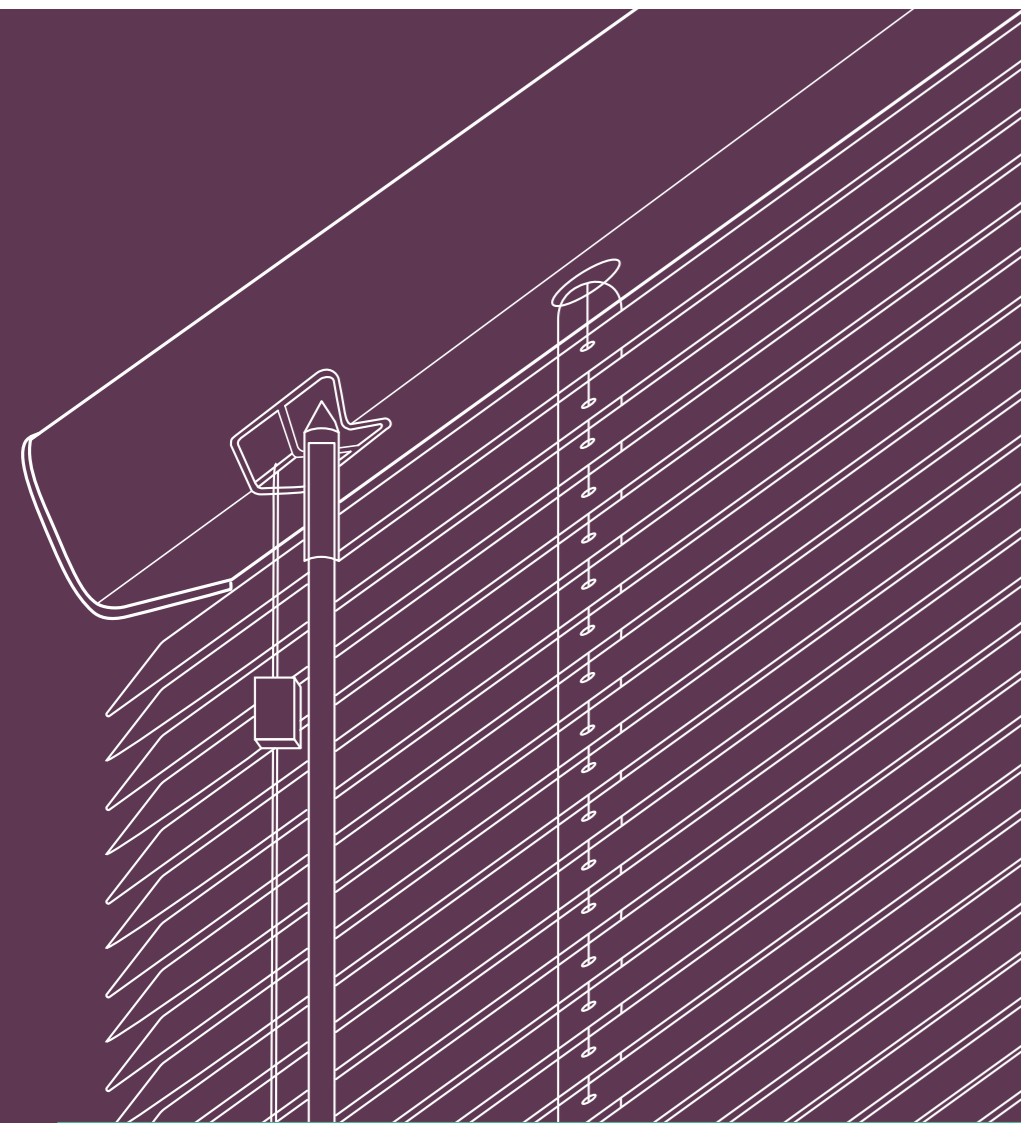

# STORES VÉNITIENS



## OPTIONS

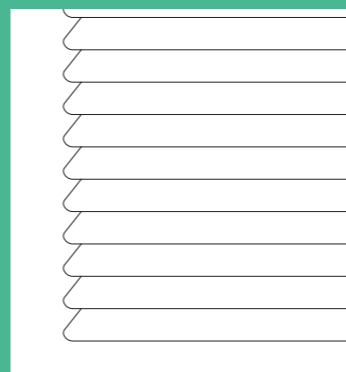

15MM, 25MM OU 50 MM

## MECANISMES

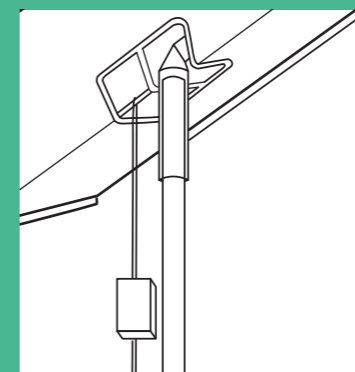

CORDON ET TIGE



MONOCOMMANDE  
CHAINETTE

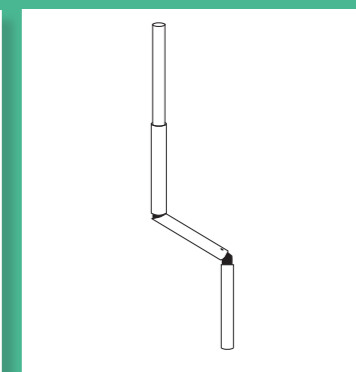

TREUIL

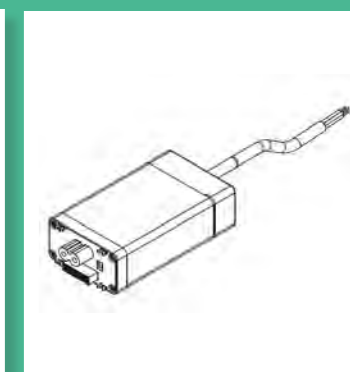

MOTEUR



**1** **Parlement Européen  
Strasbourg**  
*300 Stores-film*

**2** **Mairie de Saint Denis  
Paris**  
*1000 Stores-film*

**3** **AXA  
Bruxelles**  
*6000 Stores-film*

**4** **Amazon  
Barcelone**  
*1500 Stores Soltis*





# SOLAR SCREEN

SMART FILM SOLUTIONS

LES AUTRES FILMS SOLAR SCREEN  
 THE OTHER SOLAR SCREEN FILMS  
 DIE ANDEREN SOLAR SCREEN FOLIEN  
 OTRAS LÁMINAS SOLAR SCREEN  
 LE ALTRE PELLICOLE SOLAR SCREEN  
 ÖVRIGA FILMER FRÅN SOLAR SCREEN



**SOLAR SCREEN**  
**SOLAR CONTROL**  
 SMART SOLAR SOLUTIONS



**SOLAR SCREEN**  
**SAFETY**  
 SMART SECURE SOLUTIONS



**SOLAR SCREEN**  
**AUTOMOTIVE**  
 SMART TINTING SOLUTIONS



**SOLAR SCREEN**  
**DESIGN**  
 SMART VISUAL SOLUTIONS



**SOLAR SCREEN**  
**PRINTING**  
 SMART GRAPHIC SOLUTIONS



**SOLAR SCREEN**  
**COVER STYL'**  
 SMART INTERIOR DESIGN

SOLAR SCREEN  
 INTERNATIONAL S.A.  
 18, Rue du Commerce  
 L-3895 FOETZ (LUXEMBOURG)  
 Tél. : +352 26 00 84 82  
 Fax : +352 26 00 84 83

SOLAR SCREEN  
 FRANCE  
 8, Rue Vladimir Jankélévitch  
 F-77184 ÉMERAINVILLE (FRANCE)  
 Tél. : +33 1 64 61 64 20  
 Fax : +33 1 64 61 63 96

SOLAR SCREEN  
 DEUTSCHLAND GmbH  
 Südallee 37a  
 D-54290 TRIER (DEUTSCHLAND)  
 Tél. : +49 6502 937 940  
 Fax : +49 6502 937 9419

UFFICIO DI RAPPRESENTAZA  
 ITALIA  
 Via Antonio Pacinotti,  
 31 - 20900 MONZA (ITALIA)  
 Tél. : +39 039 57 88 023  
 Fax : +39 039 57 88 022